

Certain specification(s) are based on engineering calculations and are not actual measurements. Specification(s) are provided for comparison purposes only and are subject to change without notice. Specification(s) for your individual Doosan equipment will vary based on normal variations in design, manufacturing, operating conditions, and other factors. Pictures of Doosan units may show other than standard equipment

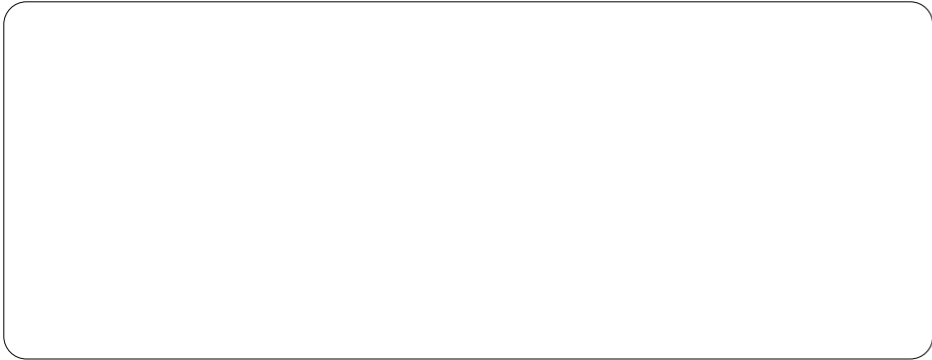

Construction Equipment

DOOSAN

SD200
SD300
SD300H



Powered by **Innovation**

DOOSAN

Hyundai Doosan Infracore

489 Injung-ro, Dong-gu, Incheon, South Korea

<http://global.doosanequipment.com>

DIPBE-00-2211

Hyundai Doosan Infracore is an affiliate of Hyundai Heavy Industries Group.
The Doosan trademark, **DOOSAN**, is used under license from Doosan Corporation.

Photos may include optional equipment

Powered by **Innovation**

SD300

PROPELLING HELPER PREPARING ALL THE WAY

BRIGHT AND VERSATILE, WITH ACCELERATED PERFORMANCE

- Reasonable match between transmission and torque converter fully play engine power enable the whole machine to deliver stronger traction.
- With 3,200mm wheelbase and 5,630mm turning radius, SD300 is specially designed for light materials. It enables greater agility and more efficient operation.

RELIABLE PARTNER WITH EFFICIENT COOLING SYSTEM

- The advanced drive axle and improved differential bevel gear have increased gear flexural strength, which enhances the reliability of the drive axle and extending its lifespan.
- By using Doosan patented technology and a redesigned layout with materials, the cooling system significantly reduces hydraulic oil and water temperature during operation.

WELL-APPOINTED INTERIOR AND WELL SECURED SAFETY

- Noise reduction technology complying with international standards provides protection and boosts work efficiency.
- Newly designed cabin is spacious and provides wider view and enhanced comfort.



SD300

RIGHT PERFORMANCE IN RIGHT PACE

PERFECTLY MATCHED POWER TRAIN

Engine, transmission and axles are optimized and finely tuned for each other and produce powerful traction.

SMALLER TURNING RADIUS AND AGILITY

Larger steering angle (40°) makes smaller turning radius. Small turning radius offers flexibility for operator to adapt in a confined space.

ACCELERATION PERFORMANCE

The injection pump has undergone special test and features greatly improved engine acceleration performance and speed.

SHORTENED HYDRAULIC SYSTEM ACTION TIME

Short system action time leads to a shorter operation cycle and greater efficiency.



ENGINE (WD10G220E23)

Greater engine outputs of 162kw and impressive torque enables to precisely deliver the power you need. The fitted engine has been adjusted to various condition and offers lower fuel consumption in commonly used operating states.

SD300

REINFORCED DURABILITY

REINFORCED PINS

The hinge pins for operating devices in 6 positions have a radius of 5-10mm larger than similar products in the industry.

DURABLE AXLE DESIGN

More durable materials and technology were applied to machining gears.

TRANSMISSION SHAFT

Double bearing supporting propeller shaft in dual configuration. Lubricating oil can be infused easily, enhancing the durability.

SOLID FRAME STRUCTURE

3D CAD and FEM technologies are adopted in the analysis of technical design. Improving the strength, durability and reliability of the device.

SWING FRAME CONNECTION

Connecting parts of swing frame adopt a reinforced design to offer greater strength.

BOX SHAPED

Rear frame side plates' box-shaped structure allows enhanced frame strength.

SOLID MAIN CONTROL VALVE

New pilot main control valve, which lowers inside leak and prolongs the service life. A pilot filter is added to increase the reliability of pilot system.

DOUBLE PUMP

CASAPPA double pump has a higher volume rate, lower failure rate, higher reliability and longer service life.

EASY MAINTENANCE

ENGINE COVER

Engine cover part is integrated in one-piece. United cover makes it easy to repair engine and sub parts.

LCD PANEL FOR ERROR CODE

LCD panel in the gauge panel shows error code and operator can recognize failures of the machine.

EASILY CHANGEABLE BREAK DISCS

The use of quick-change brake discs allows the user to check brake pads for excessive wear at any time and change the brake pads more easily without removing the tires.

BOOSTER BUMP

The booster pump delivers a higher augmented-thrust ratio and more stable braking performance.

CONVENIENT INSPECTION ON HYDRAULIC LEVEL

Monitoring the hydraulic oil level was made easier, to reduce maintenance time and to improve device service lifetime.

EASY APPROACH

Both sides of the hood can be opened to the side. Making daily oil inspection and maintenance works quicker and more convenient.



SD300 OPTIMIZED WORKSPACE

CABIN COMFORT

Ample space, wide visual field and intuitive features will guarantee a pleasant work. Cabin also offers significant noise and vibration reduction.

LED LAMP FOR IMPROVED VISIBILITY

Existing front lamp has been upgraded to LED and totally six more lights have been added. Two additional LED lights and cables on the front and four more on the back.

ENTERTAINMENT SYSTEM

MP3+radio, SD card and USB slot add enjoyment to operator's work conditions.

SHOCK PAD

A new model of shock pad is used to provide stronger durability and reduced shock and noise, effectively relieving the operator's fatigue.

ALL AROUND VISIBILITY

Improved visibility on the bottom section of the front windshield enables easy positioning of front wheels.

DELUXE SEAT

High back, deep-seated position, dual armrests and multi-level spring shock absorption guarantee a comfortable operation.



TECHNICAL SPECIFICATION (SD300)

DIMENSIONS & WORKING RANGE (SD300)

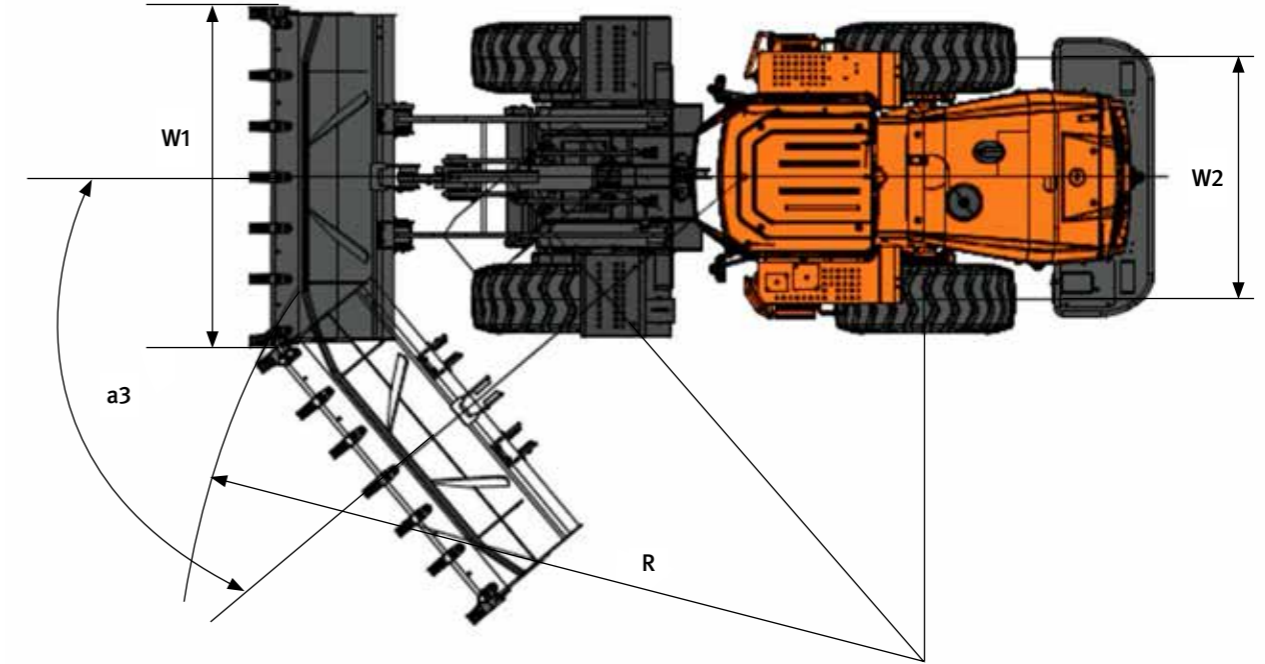
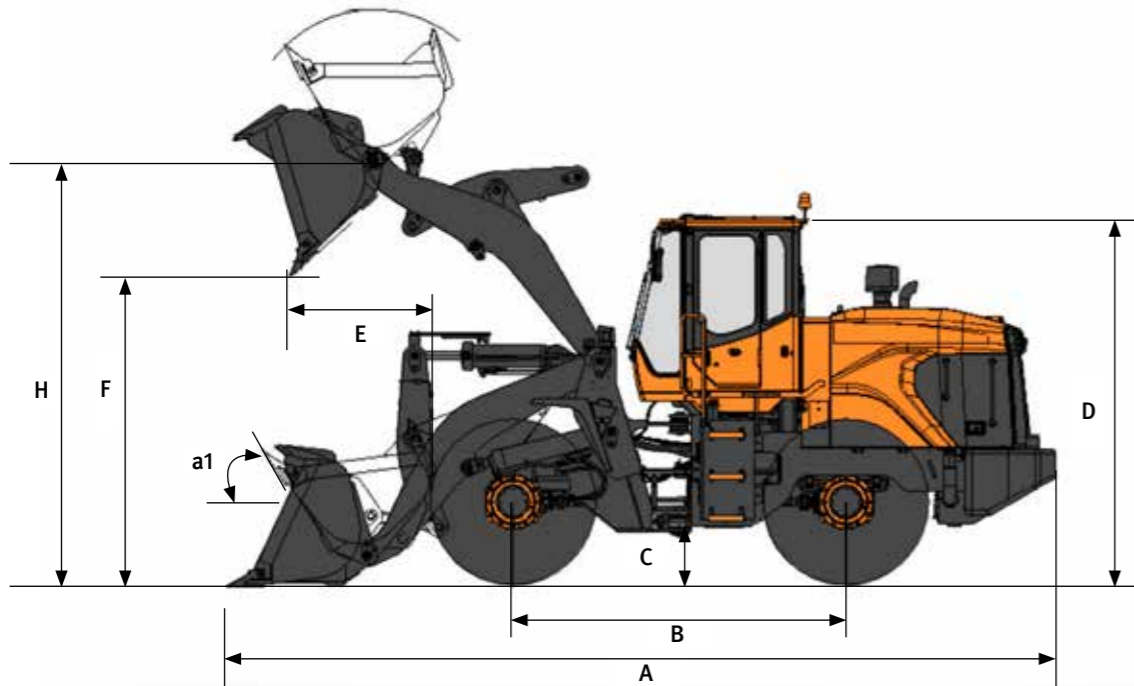

ENGINE

Model	Weichai WD10G220E23 (TIER 2)
Rated Power (SAE J1995 Gross)	92 kW (125 ps) @ 2,200 rpm
Max. Torque (SAE J1995 Gross)	500 N.m @ 1,400~1,500 rpm
Fuel Consumption	225 g/kW.h @ RATED SPEED
Number of cylinders/bores/strokes	6 / 126 mm / 130 mm
Displacement	9.7 L

HYDRAULIC SYSTEM

Main Pump Type	Fixed gear
Main Pump Displacement	104.9 cc/rev
Max. Flow Rate	215 l/min

GENERAL SPECIFICATIONS

Operating Weight	17 ton
Bucket Capacity (SAE HEAPED)	3.0 m ³
Travel Speed (1/2)	12.2 / 38 km/h
System Pressure (Work/Steer)	170/140 kg/cm ²
Payload	5,000 kg
Static Tipping Load (straight)	11,300 kg
Sound Level in CAB (ISO 6396)	85 dB (A)
External Sound Power Level (2000/14/EC)	114 dB (A)
Fuel Tank Capacity	300 L
Tire Size	23.5-25-16 PR

TRANSMISSION

Type	2 Speed, Power-shift, Planet, Engine remote mounted with propeller shaft & damper
Torque Converter Stall Ratio/Size	4.1 / 315 mm

ITEMS		UNIT	STD.	OPT 1	OPT 2	OPT 3	
Operating Weight		ton	17	17.1	17.3	17.2	
Bucket Capacity (SAE HEAPED)		m ³	3.0	3.0	2.7	4.0	
Arm			STD.	LONG	STD.	STD.	
Breakout Force		kN	164	155.82	158.76	131.32	
Dimension	Overall Length	A	mm	8,020	8,445	8,122	8,107
	Overall Width	W1	mm	2,992	2,992	2,992	3,092
	Overall Height	D	mm	3,520	3,520	3,520	3,520
	Ground Clearance	C	mm	420	420	420	420
	Wheelbase	B	mm	3,200	3,200	3,200	3,200
	Tread	W2	mm	2,174	2,174	2,174	2,174
	Working Range	Dump Height at 45° (with tooth)	F	mm	3,089	3,384	3,117
Dump Reach at 45° (with tooth)		E	mm	1,308	1,366	1,335	1,276
Max. Tilt Angle (on ground)			degree (°)	45	45	45	45
Max. Tilt Angle (at fully raised)			degree (°)	59	59	59	59
Max. Tilt Angle (at carry)		a1	degree (°)	50	50	50	50
Height at bucket pivot point		H	mm	4,150	4,450	4,150	4,150
Digging Depth (0° level)			mm	120	200	122	90
Max. Steering Angle		a3	degree (°)	40	40	40	40
Turning Radius (tire center)			mm	5,630	5,630	5,630	5,630
External radius at bucket edge		R	mm	6,470			
Gradeability		% (°)	58 (30)				